

Cultural History (Boston: Little, Brown, 1961), p. 382. Rowe's counterassessment is more solicitous of Cram's "quasi-Liberty performance, simultaneously located both in Texas and the former Exarchate of Ravenna," asking: "But, intrinsically, was it any the worse for that? From the 1930s onwards, as the social consciousness and attendant *Zeitgeist* obsessions became activated, certainly a lot of people thought so; but . . . so far as the fabric of Rice is concerned, it is not abundantly clear that their contributions were other than destructive." Rowe, "James Stirling," p. 24.

11 Burchard, *Report to the Trustees*, pp. 31, 32.

12 *Ibid.*, p. 32.

13 Stephen Fox, *Houston Architectural Guide* (Houston: American Institute of Architects, Houston Chapter, 1990), p. 121. See also "Fondren Library," *Architectural Record* 107 (June 1950), pp. 138-42.

14 McAdams Planning Consultants, Inc., "Library Facilities Planning Study for Rice University," Houston, Texas, January 1992. The study recommends that "planning for new library space at Rice should follow . . . a . . . twenty year time target" and considers "the need for additional library space . . . genuine." It suggests that studies of Fondren be undertaken to "establish its potential for expansion [and] identify . . . site constraints [that would include] massing studies of Fondren and surrounding structures to establish acceptable height and area limits." It also advocates evaluating "the various service options for a new library building . . . [and making] an officially documented 'reservation' for a library site on the proposed west quad for use in the indefinite future" (p. 20).

15 Robert Venturi, "Four Houses for *Gran Bazaar* (January-February 1982)," collected in Venturi and Denise Scott Brown, *A View From the Campidoglio: Selected Essays, 1953-1984* (New York: Rizzoli, 1984), p. 101.

16 Cram, *My Life*, pp. 126-27. Cram's eclecticism at Rice is prefigured in an account of a visit to Palermo at age 25: "Here was indeed a new thing in architecture! Roman columns, pointed arches, Byzantine mosaics, Arab inlays of marble and coloured glass, Renaissance altars and tombs, and all knit together in a perfectly harmonious and organic synthesis. After this showing, it was impossible . . . to become a purist in point of style" (p. 61). He was also appreciative of the creative regionalism of Carrère and Hasting's Ponce de León and Alcazar hotels in San Augustine, Florida (1888) for their "exuberant romanticism, . . . new picturesqueness, . . . free and easy charm" (p. 35), assembled with an imagination not usually found in the firm's work and partially explained by the involvement of Bernard Maybeck.

17 W. R. Lethaby and Harold Swainson, *The Church of Sancta Sophia, Constantinople* (London: Macmillan, 1894), p. 199. Something like Cram's regenerative "historical" rationale for the Rice style (*My Life*, pp. 125-26) can be found in Reginald Blomfield's essay "Byzantium or Lombardy," collected in *Studies in Architecture* (London: Macmillan, 1905), pp. 17, 18.

18 Etienne-Louis Boullée, "Architecture: Essai sur l'Art," translated by Helen Rosenau, ed., *Boullée and Visionary Architecture* (London: Academy Editions, 1976), p. 104.

19 Henri Labrouste succeeded in filling in the courtyard with his remodeling of the Bibliothèque Nationale (1862-68).

20 Giovanni Battista Piranesi, *Diverse Maniere d'Adornare i Cammini* (1769), p. 32, quoted in John Wilton-Ely, *The Mind and Art of Giovanni Battista Piranesi* (London: Thames and Hudson, 1978), p. 80.

21 Venturi, "Diversity, Relevance, and Representation in Historicism, or Plus ça Change . . . plus A Plea for Pattern All Over Architecture with a Postscript on my Mother's House," *Architectural Record*, June 1982, collected in *A View From the Campidoglio*, pp. 108-19.

22 Cesar Pelli and Associates, "William Marsh Rice: University Master Plan for Growth," September 1983, p. 35. Staub, Rather & Howze's initial proposal for the library extension also depicted a prominent west entrance on axis. *Sallyport*, Summer 1965, p. 7.

23 Henry Adams, *The Education of Henry Adams*, (1918; reprint ed., Boston: Houghton Mifflin, 1961), p. 340.

24 "William M. Rice Institute, Houston, Texas," *American Architect* 102 (11 December 1912), pp. 207-208.

25 Montgomery Schuyler [Franz Winkler, pseud.], "The Administration Building of the Rice Institute, Houston, Texas," *Brickbuilder* 21 (December 1912), pp. 322-24.

26 Cram, "Recent University Architecture in the United States," *Journal of the Royal Institute of British Architects*, 3rd series, vol. 19 (25 May 1912), pp. 502-503.

27 Cram, *My Life*, p. 127.

E-Z

MARGARET CULBERTSON



Permatex-covered lawn umbrella and glider by Troy Sunshade Company.

PORCH swings are pleasant, and rocking chairs are relaxing, but for me the pinnacle of porch seating is the cushioned glider of the 1930s. I encountered the perfect glider on the cool brick floor of a screened room, referred to as "the breezeway," attached to my grandparents' house in the country outside of Waxahachie. The breezeway was oriented to the prevailing wind and was bordered on two sides by a trellised walkway covered with honeysuckle, which made it the coolest space in the whole countryside. However, at the height of a Texas summer, before air conditioners became common in rural areas, even the coolest space was not exactly comfortable unless you were reclining on a cushioned glider. The slightest push of your big toe could produce both a breeze and the blessed, smooth, gliding motion that gave this inspired but unassuming piece of furniture its name.

For those familiar with this term only in reference to a kind of aircraft, a glider is a porch seat suspended from an underframe by means of short chains or metal straps that allow it to swing smoothly back and forth. It should not be confused with a porch swing, which is suspended from the ceiling. Porch swings came into use long before gliders, as did cushioned or padded variants that were referred to as "hammocks." However, these were suspended from the ceiling and consequently could not be moved easily, used in a garden or terrace setting, or adapted to grouped seating for outdoor socializing. Gliders can do all these things and at the same time allow a gentle movement that neither disturbs social conversation nor induces motion sickness.

The desire for both movement and comfort in a free-standing, movable piece of outdoor furniture that culminated in the invention of the glider produced a host of other delightful, if not totally successful, creations. Among them were the "Comfort



Front porch glider with mosquito netting, Magnolia Grove subdivision, Houston, Texas.

GLIDER

"Swing Chair" advertised in the *Ladies' Home Journal* in 1898, and many variations on a cushioned couch suspended from an overframe similar to the frame of a small swing set. The swinging couches bore a variety of names. An article in the May 1915 issue of *Gustav Stickley's Craftsman* presented one model as a "swinging hammock," another as a "swinging davenport," and a third as a "hammock with canvas-covered sea-grass mattress." A "bassinet hammock" was also pictured that would allow babies to enjoy the same outdoor swinging sensation as adults. The swinging couches were no doubt very pleasant, but the supporting framework was large and could not blend readily with other porch or sun room furniture.

In 1925 the Troy Sunshade Company advertised its new "flote-divan" as a "comfort idea never before applied to indoor furniture – a davenport with motion." The rocking mechanism, which utilized a curved-track base, was different from the suspension frames eventually used in gliders, but the result must have been the same. The advertisements promised a "silent floating effect," but the flote-divan nevertheless floated into obscurity as the glider gained popularity.

Early versions of gliders had begun to appear in the *U.S. Patent Gazette* by 1917. These proto-gliders were listed under such names as "couch-hammock," "hammock," "swinging davenport," "porch davenport," and, in the best Patent Office descriptive nomenclature, "article of furniture." The pioneering manufacturers involved in these early patents included the National Spring Bed, Rome Metallic Bedstead, Englander Spring Bed, and Enterprise Bed companies.

The use of the term "glider" for this new type of seating furniture first appeared around 1930. Other forms of the verb *glide*, which does perfectly describe the distinctive smooth, swinging motion of a glider, can be found several years earlier.



Upholstered roof-top glider modeled by George (left) and Ira Gershwin.

A glider presented in a 1925 patent was called a "glide hammock"; another, featured in a 1929 Rome furniture catalogue, was listed as a "gliding davenport"; and *Holland's Magazine* pictured one in 1930 that it described as a "gliding swing." However, "glider" is used in a 1930 patent and a 1930 advertisement in *House and Garden*. The encyclopedic 1931 Sears catalogue presented three models of the new form of seating, all labeled as "gliders." Further evidence of the term's acceptance can be found in periodicals and newspapers of the 1930s and its appearance in the 1939 edition of Webster's dictionary.

Since they were made by bed and mattress manufacturers, it is not surprising that the early cushioned gliders were so comfortable. They had coil springs beneath and sometimes in the cushions, and many models could be opened to make double beds for summer sleeping. These gliders

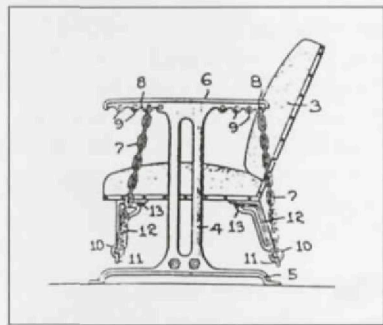

Jerome T. Atkinson, "swinging davenport," 1925.

were heavy-duty pieces of furniture designed for serious, extensive outdoor living. My uncle read *Gone With the Wind* on my grandparents' glider during the summer of 1938, a feat that would be inconceivable on a wooden porch swing or the later cushionless wood or metal gliders.

In spite of its outstanding features, the cushioned glider of the 1930s is a rarity today. Variations continued to be available through the Sears catalogue until 1964, but the frames of the postwar models were more often aluminum than sturdy steel. Changing American ways of life no longer accommodated or demanded the particular features of the cushioned glider. Maintenance had always been a problem. Cushions mildewed; springs rusted. Television began to lure more and more people inside, off their porches, as did the chilling novelty of air conditioning. Gliders are still manufactured and sold today, but they are wooden, metal, or plastic and lack cushions. Wooden gliders first appeared in the Sears catalogue in 1937, and all-metal cushionless gliders appeared in 1942. Though they lack the comfort of cushions and springs, both types are still serviceable for short periods of time. Aesthetically, the advent of the all-metal glider provided back and seat surfaces ideal for an astounding variety of punched and molded patterns – stars, basketweaves, rosettes, and



French edition of "resilient tempered steel finished in rustproof lacquer of any desired color."

bull's-eyes. The perforations in the patterns helped to keep the metal surfaces from becoming too hot and sticky; in the words of the spring 1954 Sears catalogue, they permitted the "circulation of cool, refreshing, balmy breezes."

Today, wooden gliders can be purchased at discount stores, lumber yards, and, of course, Sears. Custom models are produced by craftsmen, including the Houston firm Just-a-Swingen. Astute homeowners are searching out old gliders at garage sales and refurbishing them as part of the neo-down-to-earth revival. Although they have at times been considered a middle- or lower-middle-class phenomenon, gliders transcended all social and aesthetic bound-

aries. In the 1930s, *Country Life in America* featured wonderfully designed models; during the same period, George and Ira Gershwin, at the height of their success, were caught by the camera in front of a classic cushioned glider. Gliders reached the pinnacle of architectural endorsement when Frank Lloyd Wright acquired two for the terraces of Taliesin West.

Just about any glider can be wonderful, and I have tested many myself. But this summer I revisited the glider of my youth in its new home in San Antonio, and it is still the paragon of gliders – porch perfection personified. ■

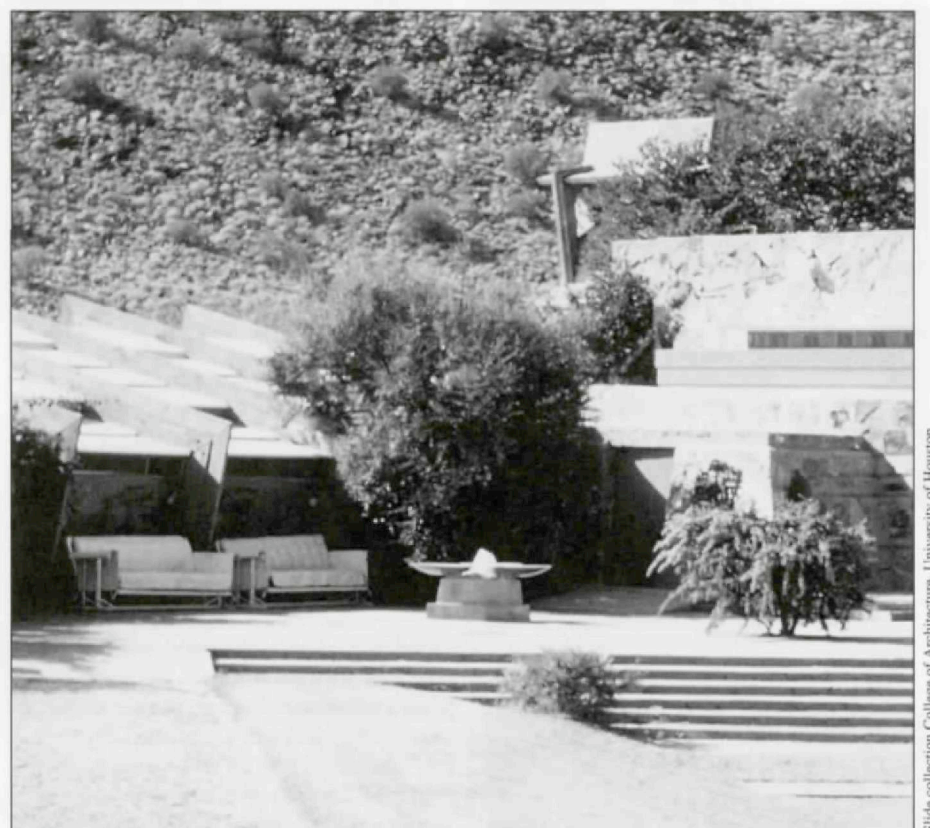

Garden room from sunset terrace, Taliesin West, Frank Lloyd Wright, 1941.